

**M-thermal Arctic
R290**



Initiating activity in

1968

Export to

200

countries and regions

Over

30

manufacturing plants
worldwide

198th

position in the ranking of
Brand Finance Global 500

245th

position in the ranking of
Fortune Global 500

199th

position in the ranking of
Forbes Global 2000

Midea Group headquarters in Guangdong China



* World's No. 1 Brand of Air Treatment Products
- according to the Euromonitor research, based on
the volume of retail sales in year 2022.



MIDEA GROUP

WORLDWIDE LEADER OF HVAC SOLUTIONS

Midea Group is the leading technological company specialized in HVAC systems, consumer equipment, industrial automation and robotics.



THE MOST COMPREHENSIVE MANUFACTURER OF HVAC APPLIANCES

- Over **57 000** technology patents
- **2.9 billion** dollars for research and development
- **28** R&D centres and labs
- Over **10 000** highly specialised engineers and experts
- **35** granted quality **certificates**
- **40+** international design awards



TOP OF THE HEAT PUMP LEAGUE – MIDEA M-THERMAL

Midea M-Thermal is a state-of-the-art technology that offers comfort and safety all year round. It is a highly energy-efficient unit for heating, cooling and domestic hot water applications. The unit works with both underfloor and radiator heating systems. In combination with fan coil units, the heat pump can provide space cooling. The units are ideal for use as advanced heating systems in new and renovated buildings, as well as in combination with bivalent systems with different heat sources such as a gas boiler.

Heating system

- 1 Solar collectors
- 2 Radiators
- 3 Indoor units
- 4 Buffer tank/DHW tank
- 5 Heat pump
- 6 Floor heating



ONE SYSTEM
=
ALL
YOUR NEEDS



TAKE ADVANTAGE OF THE SUBSIDIES

Join the "Clean Air" programme, benefit from the support plan and contribute to the reduction of pollution emitted by households.



**czyste powietrze
zdrowy wybór**

"CLEAN AIR"

The programme is intended for owners and co-owners of single-family houses or separate dwellings in single-family buildings with separate land and mortgage registers.

The programme aims to improve air quality and reduce greenhouse gas emission by replacing heat sources and improving the energy efficiency of residential buildings.

The Midea M-Thermal heat pumps meet all the requirements of the "CLEAN AIR" programme and their user can apply for subsidies. All necessary documents regarding heat pumps, that are required by the "CLEAN AIR" programme can be downloaded from the website:
List of Green Appliances and Materials
(www.lista-zum.ios.edu.pl).



PROVEN TOP QUALITY



The Keymark certificate confirms compliance with the applicable European standards set out in the Ecodesign Directive. The Keymark guarantees that the manufacturing process and the appliance itself have been tested by an independent body for efficiency in space heating, efficiency in hot water production, sound power level and safety.

In addition, Midea M-Thermal heat pumps have the following certifications:

EUROVENT



MCS



CE



OUR HEAT PUMPS WILL SOON
MAKE IT INTO THE LIST OF
GREEN APPLIANCES

Check out: www.lista-zum.ios.edu.pl



R290

NATURAL REFRIGERANT

R290, with its zero ODP value, has no negative impact on the ozone layer and its very low GWP (GWP=3) classifies it as environmentally friendly refrigerant. Thanks to the excellent thermodynamic properties of the R290 and the advanced technology, with just a small charge of refrigerant, the M-Thermal Arctic heat pumps offer excellent performance at low temperatures.



WIDE CAPACITY RANGE

Capacity (kW)		4	6	8	10	12	14	16
Power supply	220~240V-1N-50Hz	•	•	•	•	•	•	•
	380~415V-3N-50Hz					•	•	•
Appearance								

INTEGRATED BIVALENT SOURCE

As it is possible to use the additional energy provided by the built-in electric heater, both the safety of the system and the thermal comfort of the users can be increased under extreme outdoor conditions.



POWERFUL PERFORMANCE



55°C hot water supply
at -25°C outdoors



Supply temperature of up to 75°C under
extreme outdoor conditions reaching -10°C

IDEAL FOR RENOVATIONS

The main source of energy for the M-Thermal heat pump is the natural energy stored in the air. With a small amount of electricity supplied from the grid, M-Thermal can provide heat for your home. As compared to a conventional heating source, M-Thermal is a more efficient solution that combines efficiency and environmental friendliness. Its ability to operate at extreme outdoor temperatures while maintaining a very high flow temperature (75°C) makes M-Thermal ideal for replacing or retrofitting the current heat source.



TRADITIONAL
HEATING SOURCE





HEATING
WITH M-THERMAL

Natural energy	80 %
Electrical energy	20 %

HIGH RELIABILITY

The M-Thermal R290 heat pump is equipped with well-known brand components and advanced manufacturing processes, ensuring product reliability. Reliability and safety is also guaranteed for the automation components, which are housed in a hermetic cabinet, separating them from the hydraulic section of the unit.

1. ADVANCED MANUFACTURING TECHNOLOGY



2. ALL-DC INVERTER

WDC Inverter

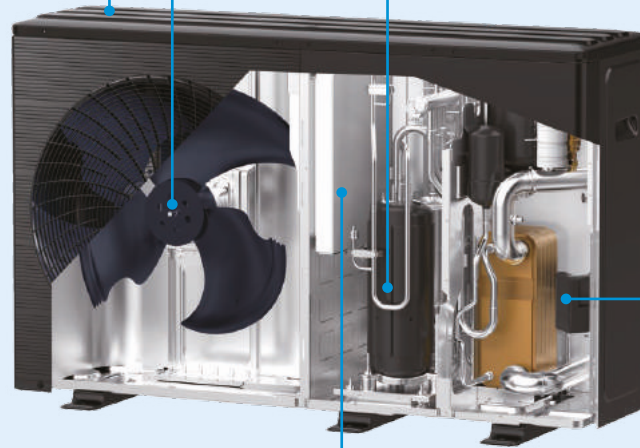
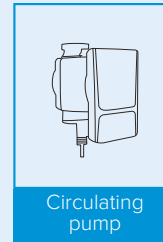
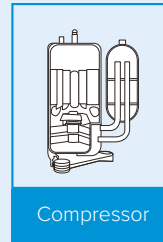
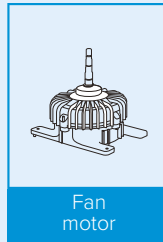

3. HERMETICALLY SEALED ELECTRICAL BOX

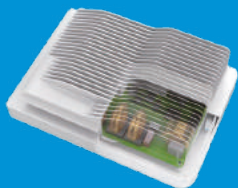

PERFECT SEALING

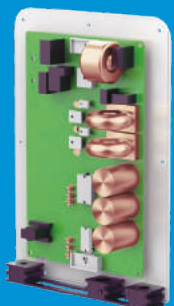

EXPLOSION PROTECTION

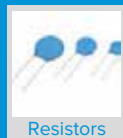

Thanks to a special air duct design and numerous simulations, the heat dissipation rate of the control system has been significantly improved, providing strong support for the heat pump and its stable operation over a wide ambient temperature range of $-25 \sim 46^{\circ}\text{C}$



Airflow simulation



Temperature distribution simulation

HIGH EFFICIENCY

The energy efficiency label indicates the efficiency level and performance data of the heat pump. It is also intended to provide users with the necessary information to make a purchasing decision on highly energy-efficient products. Thanks to the use of all DC inverter technology, the M-Thermal Arctic series, working with R290 refrigerant, achieves energy efficiency class A+++, which provides users with the best performance and comfort combined with economy.

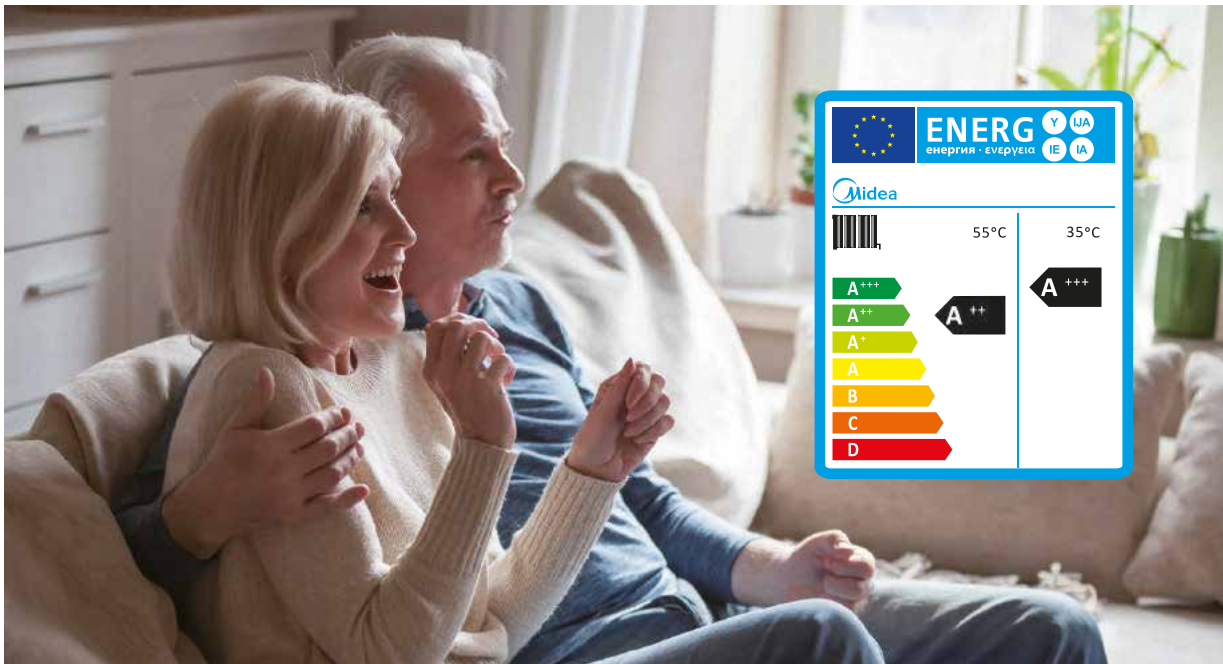

USER-FRIENDLY CONTROL



- Colour display
- Intuitive operation
- Touch control
- Liquid crystal display
- Built-in Wi-Fi module
- BMS communication (ModBUS)
- Control application

TECHNICAL DATA

Model			MHC-V4WD2N7-E30	MHC-V6WD2N7-E30	MHC-V8WD2N7-E30	MHC-V10WD2N7-E30	MHC-V12WD2RN7-E30	MHC-V14WD2RN7-E30	MHC-V16WD2RN7-E30	
Power supply			220-240V-50Hz				380-415V-3N-50Hz			
Cooling (A35W18)	Capacity	kW	4,5	6,5	8,3	10	12	14	16	
	EER	/	5,5	5,1	5,15	4,75	4,5	4,2	3,9	
Cooling (A35W7)	Capacity	kW	4,7	6,8	7,5	8,9	11,5	12,7	14	
	EER	/	3,65	3,1	3,45	3,25	3,05	2,9	2,75	
Heating (A7W35)	Capacity	kW	4,5	6,2	8,4	10	12	14	15	
	COP	/	5,15	4,9	5	4,7	4,8	4,5	4,4	
Heating (A7W45)	Capacity	kW	4,5	6,4	8,2	10	12	14	15	
	COP	/	4,05	3,8	3,85	3,65	3,7	3,5	3,35	
Heating (A7W55)	Capacity	kW	4,6	6,2	7,8	9,5	12	14	15	
	COP	/	3,2	3,1	3,2	3,05	3,1	3	2,85	
Heating (A2W35)	Capacity	kW	4,4	5,6	7,1	8,2	10,7	11,7	12,8	
	COP	/	4,1	3,9	3,85	3,65	3,5	3,35	3,2	
Heating (A-7W35)	Capacity	kW	4,5	5,9	7	8	10	11,5	12,7	
	COP	/	3,1	2,95	3	2,85	2,8	2,7	2,5	
ErP	Average climate, W35	/	A+++	A+++	A+++	A+++	A+++	A+++	A+++	
	Average climate, W55	/	A++	A++	A++	A++	A++	A++	A++	
Dimensions (H*W*D)		mm	1299*717*426			1385*865*523				
Transport dimensions (H*W*D)		mm	1375*885*475			1465*1035*560				
Weight	Net	kg	90	90	117	117	142	142	142	
	Gross	kg	110	110	139	139	164	164	164	
Acoustic power (ErP)		dB(A)	56	58	60	61	65	65	69	
Electric heater (built-in)		kW	3				3			
Water connection		inch	1"			1 1/4"				
Refrigerant	Type/GWP	/	R290/3							
	Charge	kg	0,7		1,1		1,25			
Outdoor temperature operating range	Cooling	°C	-5 - 46							
	Heating	°C	-25 - 35							
	DHW	°C	-25 - 46							
Supply water temperature range	Cooling	°C	5 - 25							
	Heating	°C	25 - 75							
	DHW	°C	20 - 70							

Data in conformity with standards EN14511; EN14825; EN50564; EN 12102; (EU) No.: 811.

DIMENSIONS

4-6 kW MODELS

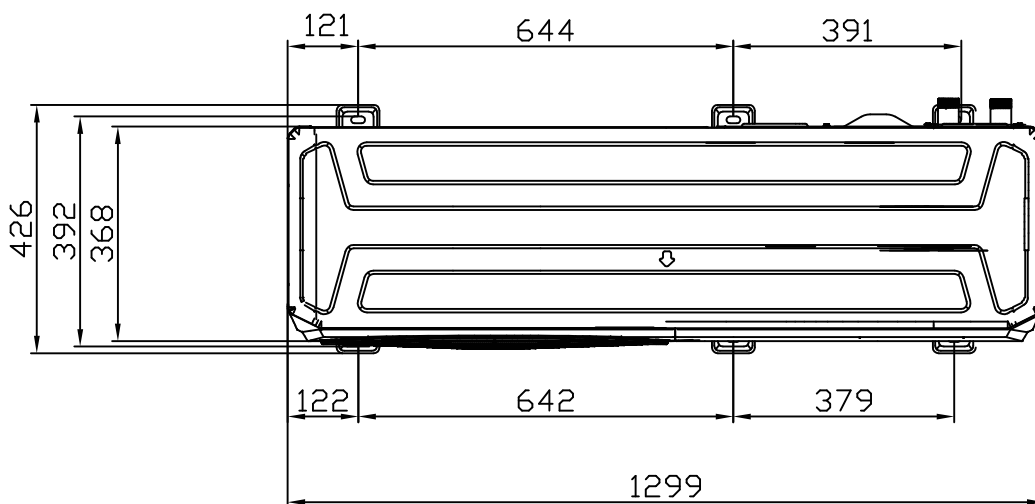
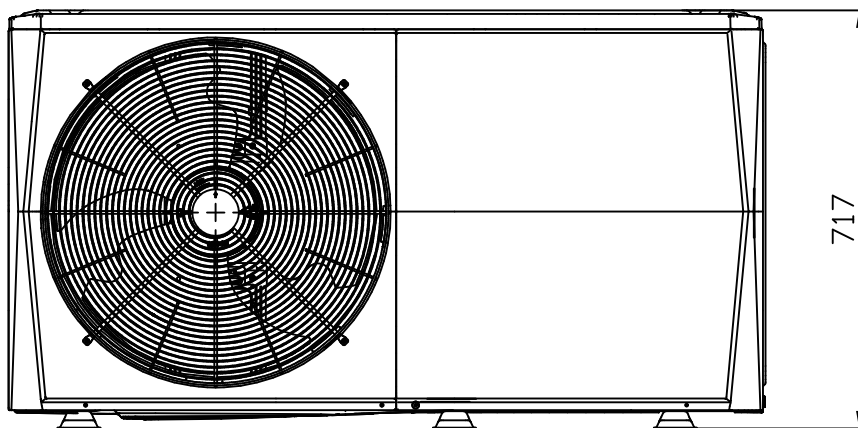
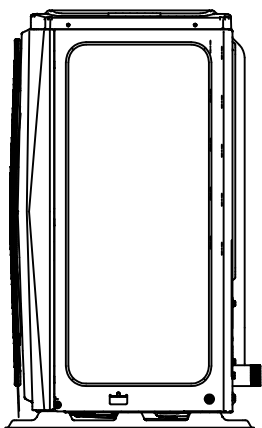

DIMENSIONS

8-16 kW MODELS

