



# AP 8 WOOFER



- 1 Water-repellent treated paper cone, featuring a profile developed with FEM (Finite Element Method) simulation technology and optimized with the Klippel Scan Vibrometer.
- 2 No passive crossover required to maximize efficiency: dome profile optimised with Klippel R&D Scan Vibrometer to obtain a calibrated mechanical low-pass cut-off frequency.
- 3 Reduced mounting depth, providing ease of installation in OEM placements.
- 4 TPU (Thermoplastic Polyurethane) surround, featuring the exclusive shallow "Triple Wave" profile, for maximum excursion linearity.
- 5 Compact basket, protected by abrasion-resistant and scratch-proof coating, the motor affixed with damping epoxy adhesive.
- 6 High current fast-on terminal with double contact on positive and negative poles for high flexibility and quick connection. The terminal features a temperature resistant plastic cover, protecting it against accidental short circuits.
- 7 Developed with the KLIPPEL suite.

\*Grille included

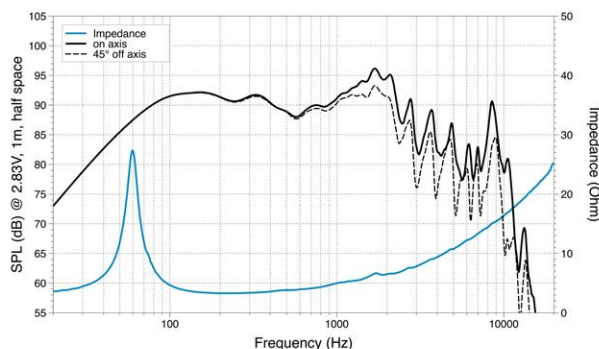
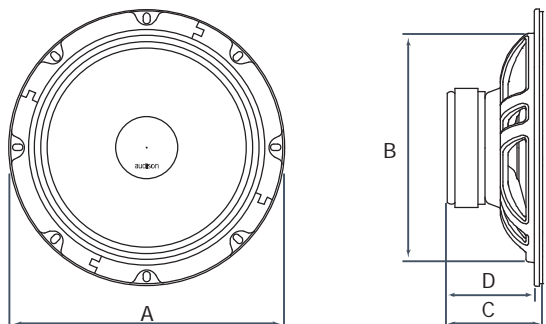

A	A <sub>3</sub>	B	C	D	
209	-	174	70	66	mm
8.23	-	6.85	2.75	2.6	in.

## TECHNICAL SPECIFICATIONS

Component		Woofer
Size	mm (inch)	200 (8)
Power Handling	W peak	300
	W continuous	100
Impedance	Ω	4
Frequency Response	Hz	35 ÷ 3k
Magnet size	mm	90 x 40 x 17
D x h	(inch)	(3.54 x 1.57 x 0.67)
Weight of one speaker	kg (lb)	1,2 (2,64)
Voice Coil Ø	mm (inch)	25 (1)

## ELECTRO-ACOUSTIC PARAMETERS

D	mm	159
Xmax	mm	±3,3
Re	Ω	3,1
Fs	Hz	60
Le	mH	0,37
Vas	l	22,6
Mms	g	18
Cms	mm/N	0,4
BL	T·m	5
Qts		0,74
Qes		0,82
Qms		7,6
Spl	dB	93,5